



100UC+

UROLOGY TABLE

Operator Manual

L100-3703 Rev B 02/2026



MADE IN THE USA

INTELLIGENT DESIGN ► **TANGIBLE OUTCOMES**

ABOUT IMAGE DIAGNOSTICS, INC.

IDI is a leading manufacturer of specialized equipment and accessories for surgical and diagnostic imaging applications. Our company focus is on mobile equipment solutions for these applications, including C-arm compatible tables and mobile video display systems. IDI is headquartered in a modern 38,000 sq. ft. facility in Fitchburg, Massachusetts, USA, where IDI products are both designed and manufactured.



ORDER: sales@imagediagnostics.com
SUPPORT: techsupport@imagediagnostics.com
WEBSITE: <https://imagediagnostics.com>

+1-978-829-0009
Monday through Friday
8am to 5pm, Eastern



OVERVIEW

The 100-UC+, along with any accessories, shall be referred to in this manual as “this equipment.” This manual is not intended as a substitute for certified training for the use of this equipment. The operation of this equipment should be limited to qualified medical personnel who have been trained in the use of medical equipment.

The text of this manual was originally written, approved, and published by the manufacturer in English. This equipment complies with applicable FDA performance standards contained in 21CFR at the date of manufacture. The device is registered with the FDA as a Class II 510K exempt device.

OWNER RESPONSIBILITIES

The owner of this equipment is responsible for ensuring system compatibility, the qualifications of operators and maintenance personnel. Operators must be properly trained and have obtained credentials from the appropriate authorities.

This equipment must be installed in an area provided with the proper electrical power. The owner of this equipment is responsible for verifying continued compliance with all applicable regulations and standards. Consult local, state, federal and/or international agencies regarding specific requirements and regulations applicable to the use of this equipment.

Image Diagnostics, Inc. certifies only this equipment. Operating practices and safety for this equipment are the sole responsibility of the owner and operators. Image Diagnostics, Inc. assumes no liability or responsibility for personal injury or damage resulting from misuse of this equipment.

Never make modifications or adjustments to this equipment unless directed by a qualified Image Diagnostics representative. This equipment, when properly manufactured, meets US federal regulations and international standards. Unauthorized modifications to this equipment may impact adherence to these standards and make this equipment unsafe to operate.

CUSTOMER SUPPORT

Image Diagnostics, Inc. may provide on request component part lists or other information to assist the user’s appropriately qualified technical personnel to repair those parts of equipment which are designated by the manufacturer as repairable.



For technical assistance, call IDI at (978) 829-0009. Be prepared to give the complete model and serial number found on the data plate on the table base at the time of contact.

TABLE OF CONTENTS

Product Data	5
Symbol Identification	6
Intended Use & Essential Performance	8
Safety Hazards	8
EMC (Electromagnetic Compatibility) Statement	11
Emergency Stop Pushbutton	11
Setup Instructions	12
Instructions For Table Operation	13
1.1. CASTER LOCKING AND UNLOCKING SETTINGS	13
1.2. TABLETOP SLEEP STATES	14
1.3. TABLETOP MOTION HANDSET CONTROLS	14
1.4. TABLETOP MOTION FOOT CONTROLS	18
Transportation Instruction	22
Patient Preparation	22
1.1. Preparation for Patient Use	22
1.2. Patient Loading	22
1.3. Preparation for Performing CPR	23
Accessories	23
General Cleaning	30
Maintenance Service And Repair	31
Troubleshooting	32
Disposal of Components	33
Product Data	34
Specifications	35
Warranty & Contact Information	39

Linak documentation can be found at their web site: www.linak-us.com
Select “Products | User manuals” and click on “Actuators & Electronics”.

The text of this manual was originally written, approved
and published by the manufacturer in English.

PRODUCT DATA

- Low attenuation carbon fiber tabletop
- Tabletop: 71cm x 118cm (28in x 46.5in)
- Imaging area, main tabletop: 73.5cm x 54.5cm (29in x 21.5in) max.
- Radiolucent tabletop extension [A100-1400]: 71/61cm x 86cm (28/24in x 34in)
- Imaging area, with optional tabletop extension: 61cm x 86cm (24in x 34in)
 - Imaging Area with optional ext.: 162.5cm x 54.5cm (64inx21.5in)
- Longitudinal travel: 35cm (13.75in)
- Trendelenburg: $\pm 12^\circ$
- Lateral travel: $\pm 88\text{mm}$ ($\pm 3.5\text{in}$)
- Height range: 74.30cm to 104.14cm (29.75in to 41.5 in) without pad
- Patient capacity: 249kg (550lbs) without tabletop extensions & accessories
- Table weight: $\sim 317.5\text{kg}$ ($\sim 700\text{lbs}$)
- Leg Boarding Tabletop Extension [A100-3543]: 71cm x 81cm (28in x 32in)
- Multi-Caster locking system: Total Lock & Unlock
- Bluetooth-compatible foot and hand operator controls
- Accessory package
- Emergency Stop Pushbutton
- Emergency Battery Backup
- One Saved Memory Position

SYMBOL IDENTIFICATION



Attention! Consult accompanying documents.
Failure to follow these instructions could cause serious personal injury or damage to equipment.



Warning! Information or instructions shown near this symbol must be adhered to in order to prevent a potentially hazardous situation which if not avoided, could result in death, personal injury or damage to the equipment.



Emergency Stop Pushbutton.



Electric Shock hazard present. Information or instructions shown near this symbol must be adhered to in order to prevent a potentially hazardous situation which if not avoided, could result in death, personal injury or damage to the equipment.



Equipotential Terminal of the table which provides for a connection between the table and the equipotential bus bar of the facility.



Recyclable material.



There is the potential of exposure to harmful x-rays. Be sure to read and comply with all warnings.



Not made with natural rubber latex.



Not for Patient Transport. The Table should never be moved with a patient on it.



Protective Ground. This is the common tie point between the AC Electrical Power Cord Ground, Frame Ground, and Controller Ground.



Patients must be loaded from the side of table. There is possible tilting or instability if patient is loaded onto the pedestal end of table or the imaging end of the table.



European Authorized Representative:

Advena Ltd. Tower Business Centre, 2nd Flr.,
Tower Street, Swatar, BKR 4013 Malta



Model of Table.



Serial Number of Table.



Indication of European Conformity for sale in the European Economic Area (EEA).



Item complying to Type B applied part per IEC 60601-1.



Date of manufacture of the device.



Location where device was manufactured.



Alternating Current (AC).



CPR (Cardiopulmonary resuscitation)





This symbol denotes that the product contains electronic devices and cannot be disposed of with household waste. This product cannot be included in municipal waste and must be disposed or recycled according to local waste regulations.

INTENDED USE & ESSENTIAL PERFORMANCE

The 100-UC+ is a mobile imaging table used by the medical industry for urological procedures. It is designed to be used in a professional healthcare environment in conjunction with “C-arm” style radiological imaging equipment. The 100-UC+ tables have backup battery power which should only be used temporarily for necessary function of the table if the external power supply is disrupted.

Functional capabilities and operation of the equipment described herein can be employed in a variety of diagnostic, therapeutic, and surgical applications. The device is designed for use as either a urological or radiographic table.

SAFETY HAZARDS

Safety Hazard Level	Potential Consequences with Use
 DANGER	Indicates an <i>imminently</i> hazardous situation which, if not avoided, will result in death or serious injury.
 WARNING	Indicates a <i>potentially</i> hazardous situation which, if not avoided, could result in death or serious injury.
 CAUTION	Indicates a <i>potentially</i> hazardous situation which, if not avoided, may result in minor or moderate injury or equipment damage.



WARNING!

This equipment has not been tested for use with high frequency surgical equipment, cardiac defibrillators, or cardiac defibrillator monitors. Use with such equipment may cause patient burns, explosion hazards or electrical shock to the patient or operator.



WARNING!

To avoid electric shock, plug the electrical power cord into a properly grounded hospital grade outlet!



WARNING!

Do not modify this equipment without authorization of the manufacturer.

**WARNING!**

This equipment may be used in conjunction with x-ray equipment. This constitutes potential exposure to harmful x-rays for both the patient and operator. Be sure to use proper radiation shielding.

**WARNING!**

If an antistatic path is required, use this equipment on an antistatic floor.
Use only the Patient Mattress Pad supplied with the table.

**WARNING!**

Move tabletop to central cross travel position when loading or unloading patient. Always safely position and secure patient on table.

**WARNING!**

Safely position and secure patient onto table.
Do not exceed table weight capacity of 550lbs (250kg).

**WARNING!**

Use of table extensions is only allowed with decreased table load. Table weight capacity reduced to 350 pounds (227kg) with only upper body on imaging extension.

**WARNING!**

Do not attempt to service/perform maintenance while the ME Equipment is in use.

**WARNING!**

To avoid possible battery leakage damage, remove internal battery if ME equipment is not to be used for at least 12 months. Battery must be recharged at least every 12 months.

**WARNING!**

Before loading a patient onto the table, always set the base casters in BOTH the FRONT and REAR to their "LOCK" positions. Confirm table is fully immobilized & locks are fully engaged prior to loading patient. Failure to do so could result in death or serious injury.

**CAUTION**

When lying on the table, patient must be restrained at all times. The restraining straps are not intended to restrain an uncontrollable patient.

**CAUTION**

The carbon fiber top is subject to damage or possible damage from impact from other objects.

Take caution when moving the table or using power driven diagnostic equipment around table. Collisions with nearby equipment can cause equipment damage or patient harm. Regular inspection of the tabletop is necessary for the safety of patient and operator.

**CAUTION**

Do not use table for patient transport.

**CAUTION**

During operation of the table, if any unusual sounds and/or erratic movement is observed, immediately discontinue use of the table.

**CAUTION**

Do not place or store any containers or large items underneath the tabletop. As the tabletop is descending, contact with an obstruction may cause permanent damage to the table.

**CAUTION**

Do not leave patient unattended on table.

**CAUTION**

Ensure that the tabletop does not contact other equipment as it moves.

**CAUTION**

If using leg holder stirrups with this table, use caution. The boot will drift if the clamp is not securely tightened.

**CAUTION**

Do not sit at the head of the table or on the table extension.

EMC (ELECTROMAGNETIC COMPATIBILITY) STATEMENT

Portable and Mobile RF Communications Equipment can affect Medical Electrical Equipment including this equipment. Use special precautions regarding EMC when these tables are installed, operated, and maintained. EMC operating parameters for these tables are in the SPECIFICATIONS section of this manual (Section 17).

The use of accessories, transducers and/or cables other than those specified, with the exception of those sold by the manufacturer as replacement parts for internal components, may result in increased emissions or decreased immunity of the equipment or system.



WARNING: This equipment should not be used adjacent to or stacked with other medical electrical equipment and that if adjacent or stacked use is necessary, the equipment or system should be observed to verify normal operation in the configuration in which it will be used.



WARNING: Portable RF communications equipment (including peripherals such as antenna cables and external antennas) should be used no closer than 30 cm (12 inches) to any part of this equipment, including cables connected to the table. Otherwise, degradation of the performance of this equipment could result.

NOTE: The emissions characteristics of this equipment make it suitable for use in industrial areas and hospitals (CISPR 11 class A). If it is used in a residential environment (for which CISPR 11 class B is normally required) this equipment might not offer adequate protection to radio-frequency communication services. The user might need to take mitigation measures, such as relocating or re-orienting the equipment.

If this equipment receives excessive electromagnetic interference, motion controls for the table may be slow or unresponsive to user inputs. In this event:

1. Verify the cause by turning nearby equipment off and retest motions. (Note: All motions will be slowed when operating on battery backup as compared to full AC power)
2. If this problem is not resolved, immediately remove power to the equipment by engaging the Emergency Stop Pushbutton as shown in section 6 of this manual.
3. Notify IDI customer service using the contact information of this manual.

EMERGENCY STOP PUSHBUTTON

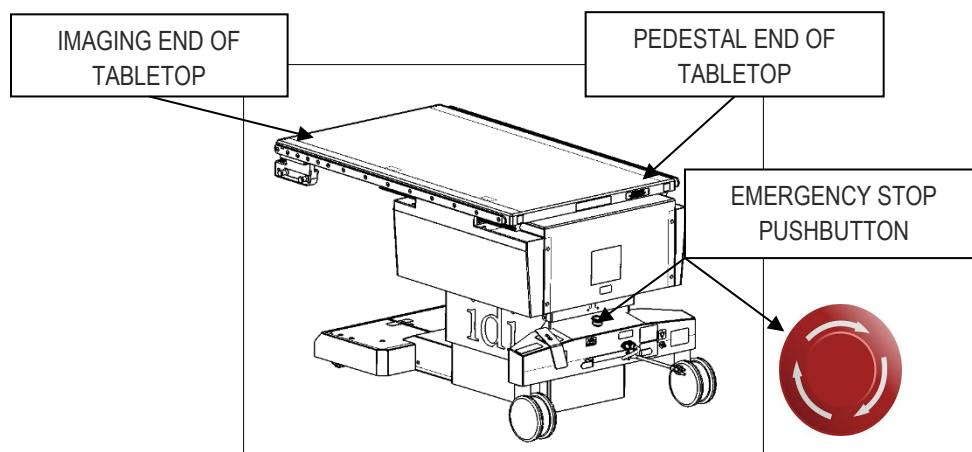

- The red Emergency Stop Pushbutton is located in the center of the base cover on the back of the table.
- Pressing this button until it is fully engaged will stop all motorized movement by cutting off power from all system components.
- RESET: Restore the electrical functions by rotating the button a quarter turn.

SETUP INSTRUCTIONS

- Hand operated controls for the movement of the tabletop are included with the table. The operator should become familiar with the controls before using them.
- External electrical power connection and disconnection is through the AC power cord and outlet. The table will operate on 120 V~, 230 V~ or on internal battery backup power (see section 8.2).
- The electrical power outlet used should be visible and accessible to the user. The electrical power cord should be routed where it will not be subject to damage or be a tripping hazard.



WARNING!

To avoid electric shock, plug the electrical power cord into a properly grounded hospital grade outlet!

Check that the ground pin on the electrical cord plug is in good condition before each time it is plugged in.

- When the table is not connected to AC power, the table will automatically switch to backup battery mode. The table should only be used under backup battery power temporarily for necessary function if the external power supply is lost.
- When positioning table for use, allow adequate clearance for power cord and power cord inlet in the event of a needed disconnect.

It is recommended that AC power be applied for a minimum of 8 hours every day to keep a proper charge on the batteries and achieve maximum battery life. Batteries are constantly being charged during normal use when connected to AC power. Batteries must be recharged at least every 12 months per manufacturer.

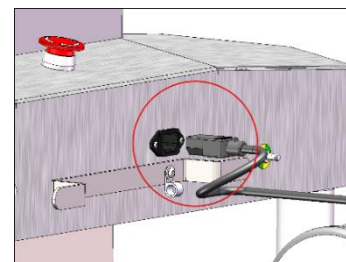

INSTRUCTIONS FOR TABLE OPERATION

1.1. CASTER LOCKING AND UNLOCKING SETTINGS

The rear casters can be configured in a locking setting which locks all motion of the rear casters and an unlocked setting which allows the rear casters to swivel freely. The front wheels can be set to total lock or swivel freely independent of the rear casters. Through combining both locking mechanisms one can completely lock out the table preparing it for patient loading.



WARNING!

Before loading a patient onto the table, always set the base casters in BOTH the FRONT AND REAR to their "LOCK" positions. Confirm table is fully immobilized prior to loading patient. Failure to do so could result in death or serious injury.

- The Table is in the "LOCK" setting when the Rear Caster Lock Pedal is pushed forward on the **TOP** half until it is fully engaged and when the Front Steer Lock is fully engaged via wireless hand control.
 - To lock front casters: Press the lock/unlock button on the handset twice within 3 seconds. The lock mechanism will start locking/unlocking and will continuously beep until it reaches that state. NOTE: Button presses in rapid succession may not be interpreted as separate by the table. For the best reliability, space button presses apart by at least one second. One additional button press may be needed to wake the table if it is in STANDBY mode.
 - **Tone will continue to be heard until front lock reaches max lock. If left between fully locked & unlocked states, all tabletop motion will be locked out & beeping tone will be heard for 15 seconds after each button press indicating mechanism needs to be fully locked prior to patient use.** If mechanism is fully locked/unlocked tone will cease immediately. Please see controller section for visual indication of front lock unlocked state.
 - To lock rear casters: depress rear pedal **TOP** half until it is fully engaged.
- When successfully locked the Rear Casters will be totally locked and will not roll in any direction while the front locking system will prevent full rotation of the table. **Always lock all casters in this way before loading the patient onto the table. First lock front caster lock and lightly push on table to verify front locking system is fully engaged prior to patient loading. Next, lock the rear lock and repeat the process.**
- The table is in the "UNLOCK" setting when the Rear Caster Lock Pedal is pushed down on the **BOTTOM** half until it is fully engaged and when the Front Locking Roller is fully lifted to disengage the unidirectional wheels and engage the free swiveling casters. The Rear and Front Casters will be allowed to roll and swivel in any direction. Lightly push on table to verify locking system is fully disengaged prior to transport.

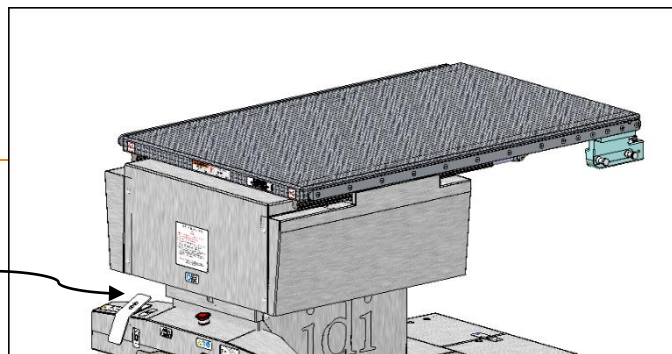

1.2. TABLETOP SLEEP STATES

All 100-UC+ tables are equipped with automatic sleep state settings to assist in minimizing system power consumption.

State Change	Timing From Standby	Wake From State
ON to STANDBY	120 Sec.	Wireless Keypress
STANDBY to SLEEP (A)	4 hr.	Wireless Keypress
SLEEP to OFF (B)	1.5 dy.	<ul style="list-style-type: none"> • Power Cycle Table (unplug and plug back in) • A wired control keypress

- If overall battery level reaches low level (<10%) in any state, system will go directly to "OFF" immediately.

1.3. TABLETOP MOTION HANDSET CONTROLS

All 100-UC+ tables are equipped with tabletop motion control boxes that allow users to move the tabletop in many different directions.

*Please Note: Unlocking the front caster lock will prevent all tabletop motions. Verify system is fully locked in order to pan tabletop.

Part Number: K000-0389+ label L100-3733



WARNING!
The Handset Control is always active when connected to a powered-up table.

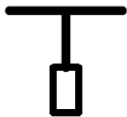
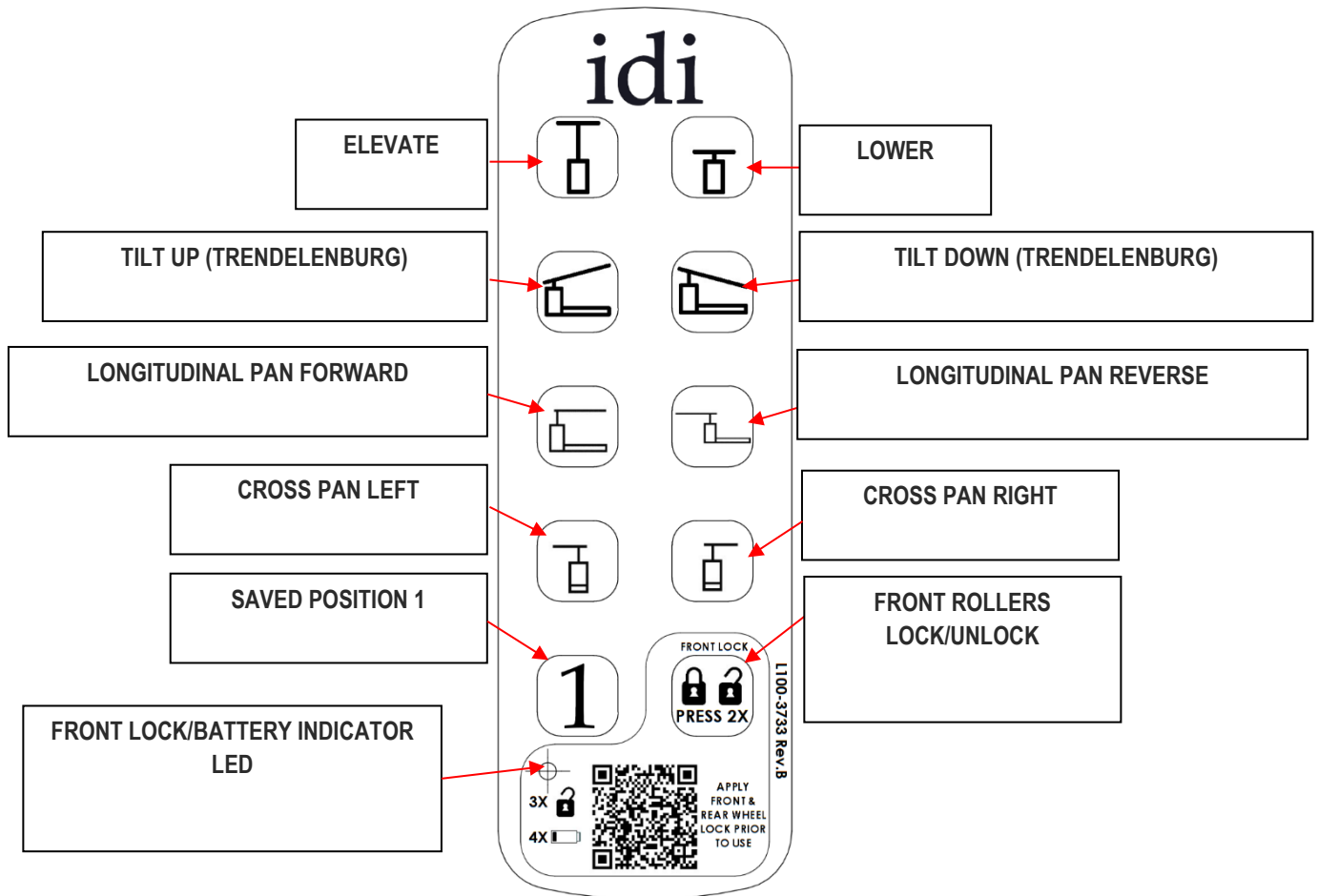

Continually pressing down on this symbol will **raise** the Tabletop **vertically**.



Continually pressing down on this symbol will **lower** the Tabletop **vertically**.

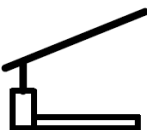

Continually pressing down on this symbol will **tilt up** the imaging end of the Tabletop in a **Trendelenburg direction**. When the Tabletop reaches a level position, motion will stop for 1 second. When the button is pressed down if the Tabletop is already in a level position, it will take 1 second for motion to begin.



Continually pressing down on this symbol will **tilt down** the imaging end of the Tabletop in a **Trendelenburg direction**. When the Tabletop reaches a level position, motion will stop for 1 second. When the button

is pressed down if the Tabletop is already in a level position, it will take 1 second for motion to begin.

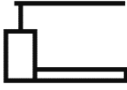

Continually pressing down on this symbol will **pan forward** the imaging end of the Tabletop, moving it away from the column end of the table.

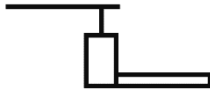

Continually pressing down on this symbol will **pan back** the imaging end of the Tabletop, moving it closer to the column end of the table.



Continually pressing down on this symbol will **cross pan left** the imaging end of the Tabletop. When the Tabletop reaches a center position, motion will stop for 1 second. When the button is pressed down if the Tabletop is already in a centered position, it will take 1 second for motion to begin.



Continually pressing down on this symbol will **cross pan right** the imaging end of the Tabletop. When the Tabletop reaches a center position, motion will stop for 1 second. When the button is pressed down if the Tabletop is already in a centered position, it will take 1 second for motion to begin.



Continually pressing down on this symbol will move the tabletop to user **Programmed Save Position 1**.



Pressing this symbol twice within three seconds will move the **front locking rollers** in one direction until reaching front lock engaged/disengaged state. Once reaching max/min repeating the double press will cause front locking rollers to travel in the opposite direction until max/min is reached. Motion will not reverse until full front lock or unlock is reached. Tabletop panning will not function until front lock is engaged.

Programming Saved Position:

To save a position on the Position one button:

- Verify that the table is on, and E-stop disengaged.
- Move the table to desired position to be saved
- Depress both saved position key & front locking key at the same time for about 5 seconds.
- Release both keys at the same time
- Press the saved position button to confirm

To test: move the table to a new position and hold down the programmed save position key. The table should move to the desired position. If the table does not move to the desired position repeat the process above. If further troubleshooting is needed, call idi helpdesk.

Pairing The Bluetooth Hand Controller:

- Verify that the table is on and E-stop disengaged.
- Move within two meters of the unit
- Enter direct pairing mode by activating key 1 and pressing magnet to the zone highlighted below in 3 seconds.
- Release key and magnet and move closer to the unit until buzzer frequency changes from slow to fast.
- Confirm pairing by pushing key 1 (highlighted below)
- A confirmation beep should indicate successful pairing

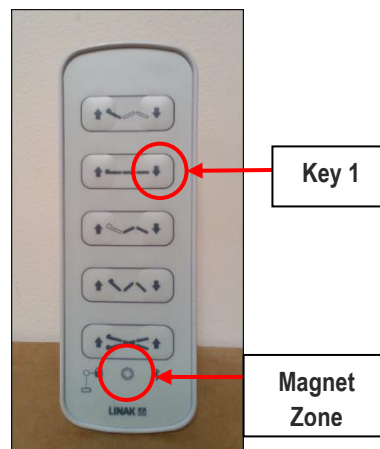

For further pairing info visit: <https://www.linak-us.com/segments/medline-careline/tech-and-trends/wireless-pairing/> and view the handset pdf.

Front Lock Indication:

- Battery indicator icon on the wireless hand control will flash when the front lock is not fully engaged. When front casters aren't in the fully locked position, LED will flash quickly 3 times when a key is pressed. **Confirm table is immobile prior to loading patient by ensuring front and rear locks are fully engaged.** *Please note: When hand control has low battery, low battery LED pattern will occur first followed by front pedal locking led pattern.* It is recommended to leave at least 1 second of time in between button presses while reading LED.
 - **LED/Tone will continue until front lock reaches max lock. If left between fully locked & unlocked states, all tabletop motion will be locked out & beeping tone will be heard for 30 seconds after each button press indicating mechanism needs to be fully locked prior to patient use. If mechanism is fully locked/unlocked tone will cease immediately.**

Low Battery Indication:

- Battery indicator icon on the wireless hand control will flash when the battery reaches a low status. When the battery falls below 20%, the LED will flash slowly 4 times when a key is pressed. It is recommended to change the controller battery prior to next use. Please note: When hand control has low battery, low battery LED pattern will occur first followed by front caster locking led pattern.
- When the controller has approximately 10% battery remaining, any input on the controller with low battery will emit an audible double beep signal from the control box internal to the table base. When the tone is audible it is recommended to change the controller battery prior to next use.
- Alternatively download the OneConnect App: the app will state “accessory low battery” when Bluetooth controller is low.
- (Bluetooth Hand Control utilizes CR2032 3V coin cell batteries. IDI recommends only using batteries with a no leak guarantee or equivalent.)

Resetting table with wireless controller: In rare cases the table control system might need to be reset. This is usually indicated by a beep and lack of movement whenever an input on the hand control is pressed. (Please verify that controller battery is not low and isn't the source of the tone). To perform a reset:

- Verify that there is no patient present on the tabletop
- hold the two buttons of the second row on hand control at the same time until four fast tones are heard
- hold the top two button on hand control at the same time until four fast tones are heard
- When the tones cease, release the top two buttons at the same time
- A slow repetitive tone should be heard indicating homing procedure has initiated
- Fully extend the front locking actuator to its limit (tabletop motions should unlock)
- While slow tone is audible, lower the tabletop to its limit
- Trendelenburg down the tabletop to its limit
- Reverse Pan the tabletop to its limit
- Cross Pan the table left to its limit
- With all actuators at their minimum limit, wait for the tone to cease. Then attempt all table motions.

1.4. TABLETOP MOTION FOOT CONTROLS

All 100-UC+ tables are equipped with tabletop motion control boxes that allow users to move the tabletop in many different directions.

Part Number: A100-3715 Disposable Covers: C000-0492



WARNING!

The Foot Control is always active when connected to a powered-up table.

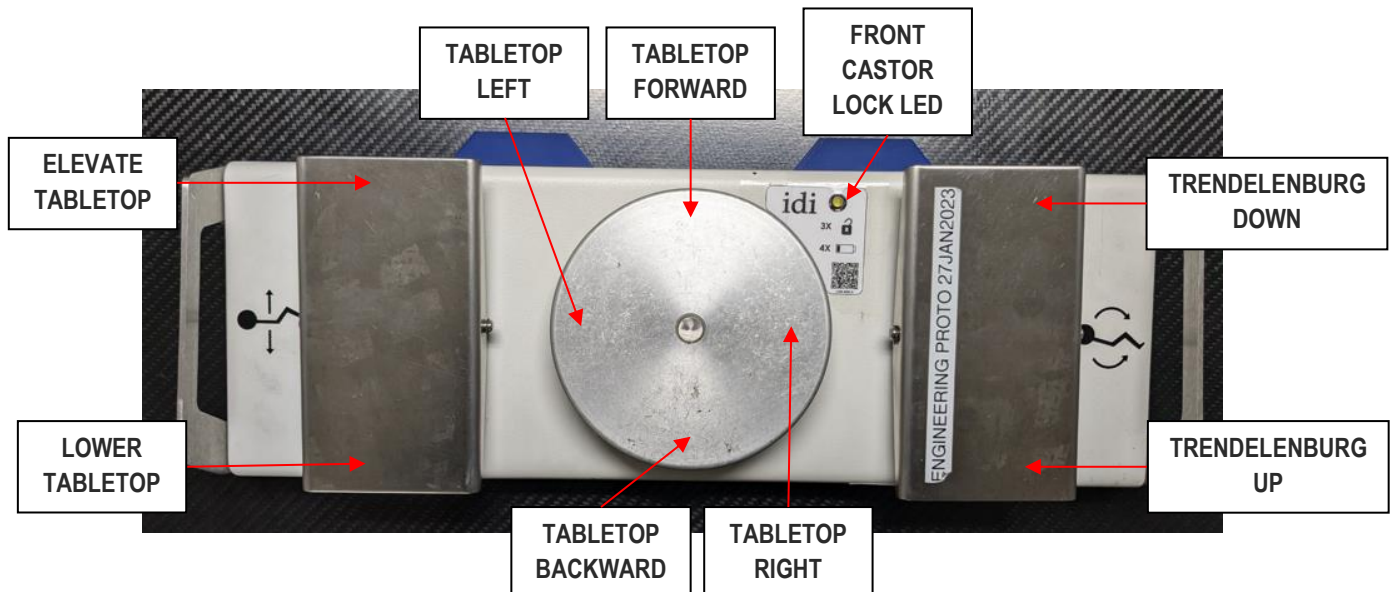

To move tabletop, depress disc or button and hold depressed until desired position is reached.

The tabletop will pause at the horizontally level position during Trendelenburg motion. Release and activate control again to continue past level. The same is true for cross travel motion. As the position of the patient's head may be at either end of the table, the action may be opposite to what is indicated by the label on the control.

- It is recommended to use disposable foot control cover to keep control clean and functional.

Note: The center disc (and the shaft attached to it) can be pulled out during cleaning, if desired, and then simply pushed back into place. Keep excessive liquids/cleaners away from center hole as such may lead to functionality issues with the foot control.

Pairing Bluetooth Foot Controller:

- Verify that the table is on and E-stop disengaged.
- Move within two meters of the unit
- Open back Cover and locate the Direct Pairing Button (highlighted below)
- Enter direct pairing mode by activating Direct Pairing Button for 3 seconds.
- Release button and move closer to the unit until buzzer frequency changes from slow to fast.
- Confirm pairing by pushing Direct Pairing Button (highlighted below)
- A confirmation beep should indicate successful pairing

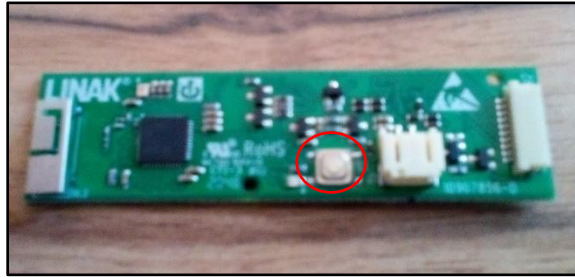

For further pairing info visit: <https://www.linak-us.com/segments/medline-careline/tech-and-trends/wireless-pairing/> and view the handset pdf.

Front Lock Indication:

- **Led Indicator:** Battery indicator icon on the wireless foot control will flash when the front lock is not fully engaged. When front casters aren't in the fully locked position, LED will flash quickly 3 times when a key is pressed. It is recommended to leave at least 1 second of time in between button presses while reading LED.
 - **Confirm table is immobile prior to loading patient.**
 - Please note: When hand control has low battery, low battery LED pattern will occur first followed by front pedal locking led pattern.
- **Front Lock with Foot Control:** Unlocking of the front caster lock should be primarily performed with the Bluetooth hand controller. In the event that the Bluetooth hand controller isn't available, one can use the foot control for temporary locking and unlocking of the front lock only.
 - To initiate front lock via foot control: press/hold lower tabletop and Trendelenburg Down buttons for about 20 seconds. If done correctly the Trendelenburg down button should now function the same as The Front Rollers Lock/Unlock key on the hand control. Pressing any button other than Trendelenburg down will cause the controls to revert to their regular functions.
 - **LED/Tone will continue until front lock reaches max lock. If left between fully locked & unlocked states, all tabletop motion will be locked out & LED/beeping tone will be heard for 30 seconds after each button press indicating mechanism needs to be fully locked prior to patient use. If mechanism is fully locked/unlocked tone will cease immediately.**
 - **Confirm table is immobile prior to loading patient by ensuring front and rear locks are fully engaged.** Please note: When hand control has low battery, low battery LED pattern will occur first followed by front pedal locking led pattern.

Low Battery Indication:

- When the controller has approximately 10% battery remaining, any input on the controller with low battery will emit an audible double beep signal from the control box internal to the table base. When the tone is audible it is recommended to change the controller battery prior to next use.
- Alternatively download the OneConnect App: the app will state “accessory low battery” when Bluetooth controller is low.
- (Bluetooth Foot Control utilizes 2X AAA 1.5V batteries. IDI recommends only using batteries with a no leak guarantee or equivalent.)

Battery replacement:

- Remove four Phillips head screws from the bottom of the unit & remove the smaller section of the bottom cover.
- Identify battery box, slide cover off and replace batteries.
- Bluetooth Foot Control utilizes 2X AAA 1.5V batteries. IDI recommends only using batteries with a no leak guarantee or equivalent.



Disposable cover not made with natural rubber latex.



One Time Use Only

COVER DISPOSAL:

Per facility procedures.

Foot Control Disposable Cover

Part Number C000-0492 (Box of 50)

Contact IDI Customer Service for individual components of foot control as needed.

Foot Control

Part Number A100-3715



TRANSPORTATION INSTRUCTION



CAUTION

Do not use table for patient transport.

- Table is not to be used for patient transportation.
- Before transporting, make sure to return tabletop to Trendelenburg level, lower the tabletop to its minimum height, and retract lateral and longitudinal panning tabletop motions to their mid travel or less.

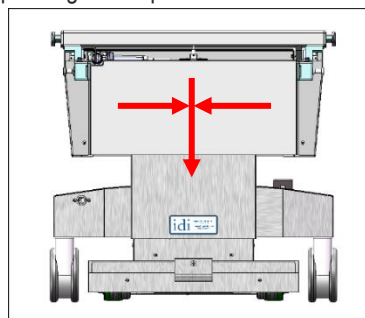
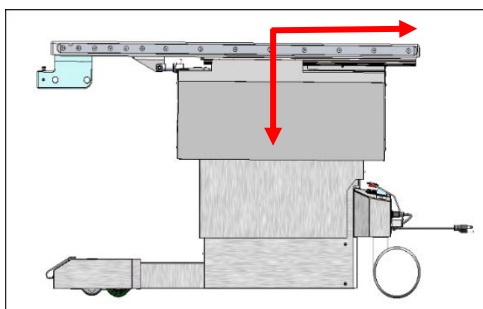

PATIENT PREPARATION

1.1. Preparation for Patient Use

- New Installation: This equipment will need to be properly cleaned before patient use as it will inevitably come into contact with contaminants during shipping, unpacking, storage, and installation.
- After initial use, this equipment will need to be properly cleaned between uses with patients as it will inevitably come into contact with contaminants during procedures. Refer to General Cleaning Section of this manual for cleaning instructions and approved cleaning substances.

1.2. Patient Loading



WARNING!

Before loading a patient onto the table, always set the base casters in BOTH the FRONT AND REAR to their "LOCK" positions. Confirm table is fully immobilized prior to loading patient. Failure to do so could result in death or serious injury.

- Patients **must** be loaded from the side of table and front/rear caster locks must be deployed. There is a possibility of tilting, instability and/or tipping if patient is loaded onto the pedestal end or the imaging end of the table.
- To reduce potential motion during patient transfers with larger patients, move the tabletop lateral (side to side) in the direction the patient will be moving until the limit of the tabletop travel is reached then transfer the patient onto the Table.



1.3. Preparation for Performing CPR

- Return table to level position, retract tabletop to minimize overhang and lower table position to a comfortable height before performing CPR on a patient. Image Diagnostics recommends **prior to placing table into service, facility/operators create a procedure for positioning the table for possible CPR events.** CPR should **not** be performed on the 100UC Tabletop Extension.



ACCESSORIES

1.1. Wired Hand Control

Controls height up/down, Trendelenburg/reverse, slide, cross table movements.

Wired Hand Control: K000-0299



1.2. Patient Mattress Pad for Tabletop

The Patient Mattress Pad is held in place by hook and loop fasteners. To remove the pad, simply pull pad up gently to remove. Replacement pads are supplied with new self-adhesive fasteners installed and new adhesive backed mating pieces for the tabletop. Peel off old fasteners from tabletop and install new pad.



Tabletop Pad 2" thick: Part Number X100-1818
C000-0645

Disposable Tabletop Pad Protector:

Note: Pad complies with California Technical Bulletin 117.

1.3. Patient Restraint Straps



WARNING!

Strap configuration is recommended; however, patient restraint is a case-by-case condition. Please refer to facility's policy on restraining a patient.

Patient Restraint Straps are recommended to be used in the following way: the whole strap drapes over the Tabletop, hangs down between the rails and the tabletop and wrapped over the outside of the rails to meet over the top of the table. If the strap is to be used along section or extension without accessory rail, slide the strap over the end of the table with the thin part of the strap over the Tabletop and the thicker part under the tabletop. The ends of the strap meet over the top of the table and connect with hook and loop fasteners. **Patient Restraint Strap Set: Part Number A100-3731 (two straps & one pad)**

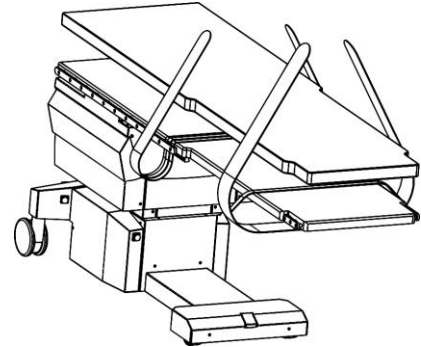

1.4. Imaging & Leg Boarding Extensions

This table is equipped with extensions that may be attached to one end of the tabletop for different functions.

Note: Before installing the extension, make sure the end of the table is free from obstructions. Remove anything hanging over the end such as cables, drapes, sheets, patient gowns, and other material.



WARNING!

Each extension is rated to support a maximum weight of 90.7 kg (200 lbs). Do not exceed limit.

Never allow the patient to sit on extensions.

Imaging Extension: Upper Body on extension: 158kg (350lb) limit / Load Capacity on extension only: 90.7kg (200lb) limit

To attach the imaging extension to the tabletop, slide the extension onto the tabletop accessory rails with the extension held at a slight angle as shown. Bring the end of the extension level as the extension fully engages. Try to pull the extension straight back after installing to make sure that it is fully locked in place.

Imaging Extension Part Number: A100-1400 [Metric Tables A100-2675] Imaging Area 61cm x 86cm (24in x 34in)

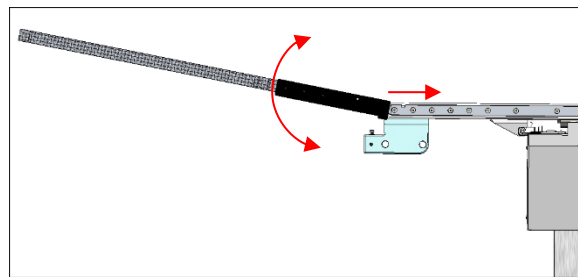
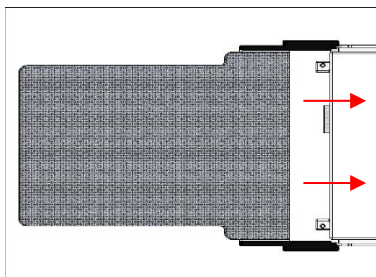

Leg Boarding Extension: Load Capacity 90kg (200lb) limit

To attach the leg boarding extension to the table, slide the extension onto the accessory pins with the extension held at a slight angle as shown. Bring the end of the extension level as the extension fully engages. Try to pull the extension straight back after installing to make sure that it is fully locked in place.

Extension not for procedural use, initial setup/loading of legs only. Before moving tabletop away from level positioning remove leg boarding extension.

Leg Boarding Extension Part Number: A100-3543

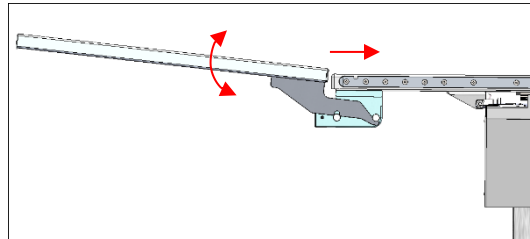
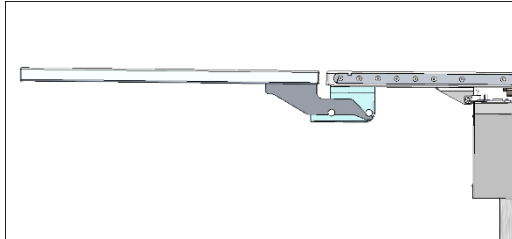
***CAUTION***

**Verify extension is locked in place before using.
Observe position of extension during table movement to
avoid collisions.**

1.5. Accessory Rail Clamps



CAUTION
Tighten all clamps before patient use.



Accessory Rail Stirrup Clamp: C000-0566 Accommodates a round accessory post. All metal design clamp mounts and locks anywhere on standard OR table rail. Autoclavable.



Simple clamp: C100-3046 Accommodates a round accessory post. All metal design clamp mounts and locks anywhere on standard OR table rail. Autoclavable.



Snap-on Blade Clamp: C100-3043 Accommodates a blade-style accessory post. Quickly snaps onto rail, push button to release clamp. Mounts and locks anywhere on standard OR table rail. Prevents false rail engagement. Autoclavable.

1.6. Arm Board

Armboard: A310-056 A310-062 Metric Quick-release, rail mounted (requires Clamp-on Accessory Rail A100-1007 or A100-2379 for use on tabletop extensions. **Replacement Armboard Pad: C100-3329 Replacement Armboard**

Strap: C000-0455



1.7. Radiation Shield

Radiation shield: A610-0341 (0.5mm Pb Eq) is easily installed by dropping tabs into the notches located in drain bag blocks. For proper Cleaning Procedure refer to General Cleaning Section.

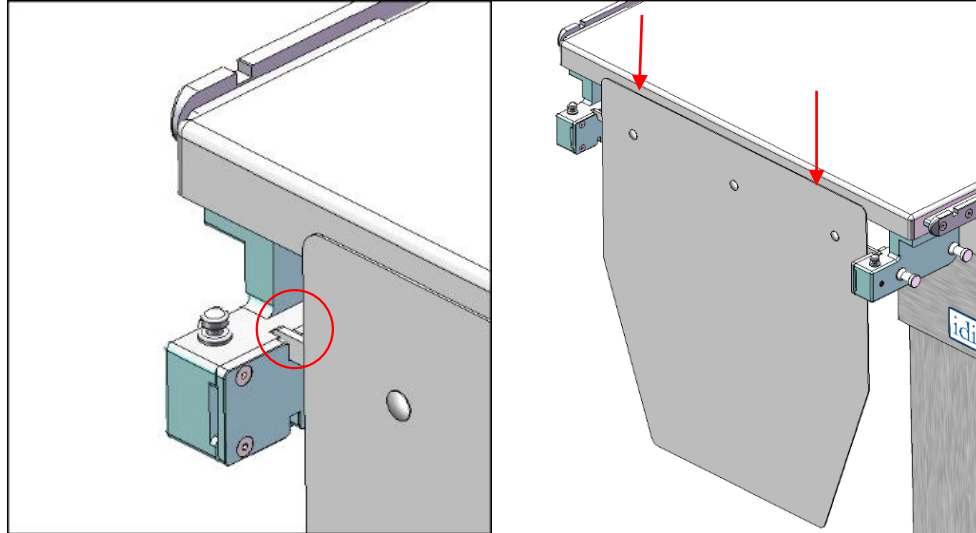

WARNING!

Radiation shields require careful handling and periodic testing for safe use.

Test upon receipt and at regular intervals to ensure shielding integrity. Test procedure and schedule to be the responsibility of the appropriate department of the facility where used.



IDI imaging tables are designed to provide excellent fluoroscopic imaging access with mobile C-arms. Whenever the table is used for procedures involving the use of a mobile C-arm, or any other equipment that produces ionizing radiation, all radiation safety standards and precautions should be applied, including but not limited to proper use of X-ray protective shielding for patients, operators and support personnel.

1.8. Drainbag Assembly

Uro Drainbag with Hose: C000-0593 (sterile) / C000-1111 (non-sterile) are intended for **one time use** collection of bodily fluids. Drainbag Hoop: Z100-3359

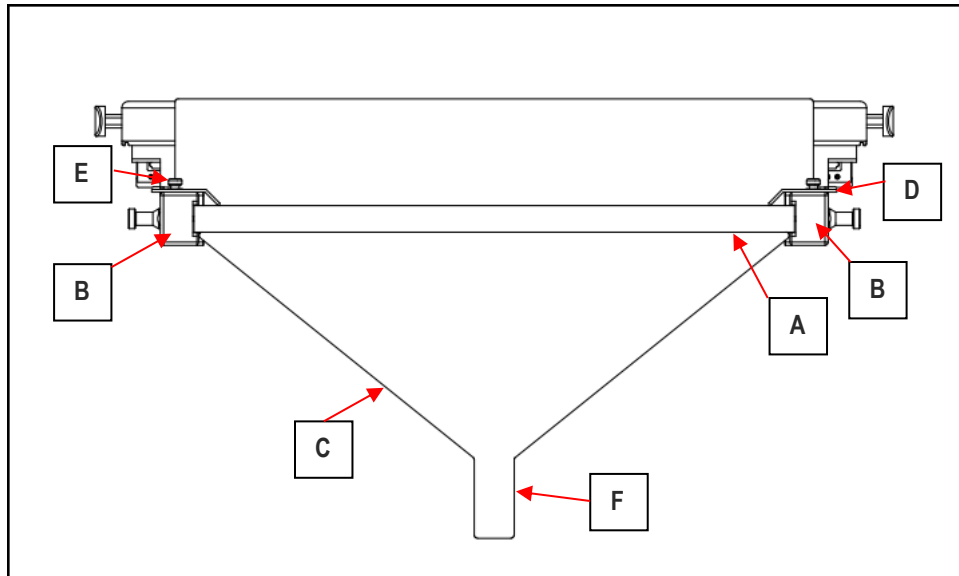

CAUTION!

Do not leave drain bag support hoop fully pressed into drain bag blocks for more than 1 hr. Excessive bends for prolonged time can lead to permanent hoop deformation.

Installation:

1. Remove tabletop Pad.
2. Slide each end of drain bag support hoop (A) into drain bag block slots (B) until internal spring pin engages. Make sure hoop face with angle faces outward on both sides when inserting.
3. Drop drain bag body (C) through hoop, while pulling drain bag edge hood over hoop's outer edge.
4. Grasp tab strips (D) of drain bag. Align holes with pins (E) on end of table and pull over pins to secure.
5. Return tabletop pad back to the tabletop.
6. Connect hose (F) to collection system.

Removal:

1. Pull plastic tab strips (D) off support pins (E).
2. Pull out drain bag support.

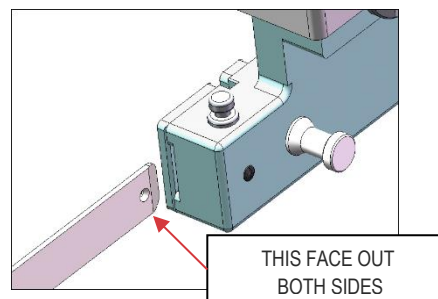

Drain Bag Hoop Storage:

1. Drain Bag Hoop may be stored in its regular use configuration with both ends in drain bag block slots, with internal spring pins locking hoop in position
2. Alternatively Drainbag hoops may be laid flat or hung vertically with a mounting pin through the hole in the end of the hoop.
3. If slight deformation occurs, hoop may be laid flat or hung vertically for 24 hours. In some cases, the hoop will relax back to its flattened state. If hoop does not return to its relaxed state or if hoop appears to have any structurally effecting deformation, hoop should be discarded and a replacement one should be ordered.



Not made with natural rubber latex.



Dispose Per Local Procedures

1.9. List of Consumables

- **Vinyl Urology Table Covers: C000-0645** Box of 20
- **Uro Drain Bags with Hose Sterile: C000-0593 Non Sterile: C000-1111** Box of 20
- **Disposable Covers for Foot Controls: C000-0492** Box of 50
- **Uro Drainbag Support Hoop: Z100-3359**
- **3"/76mm Restraint Straps (Pair): C000-0571**
- **Uro Collection Unit: 5 gal/18.9 L: C000-0612** Box of 10
- **Uro Collection Unit: 4 gal/15 L: C000-1307** Box of 10

GENERAL CLEANING

After each medical procedure, the table should be properly cleaned. Do not use harsh abrasives, solvents, sprays, or corrosive agents. Some accessories may come with individual cleaning instructions.

APPROVED AND TESTED DISINFECTANT CLEANERS FOR TABLE:

- Sodium hypochlorite (generic household bleach) in solution of 5.25% sodium hypochlorite diluted between 1:10 and 1:100 with water.
- Alcohol (generic).
- Envirocide ® Disinfectant and Cleaner.

APPROVED AND TESTED DISINFECTANT CLEANER FOR RADIATION SHIELD:

- Scrubbles® (Infab Corporation)
<https://www.infabcorp.com/apron-cleaning/>

APPROVED AND TESTED GENERAL-PURPOSE CLEANERS:

- Simple Green™ cleaner.

CLEANING STEPS FOR TABLE:

Please note: Avoid using cleaners or wiping bearing rail surfaces. Wiping these surfaces may remove surface level lubricants that could effect tabletop panning performance.

- Move the tabletop to a level horizontal position.
- Lower the tabletop to its lowest position.
- Disconnect the table from the AC power outlet and press the Emergency Stop Pushbutton.
- Power cord, Handset Control and Foot Control cords must be plugged in at the table base to protect the inside of the connectors from debris.
- Remove all pads and accessories.
- Wipe off any excess fluids with a water dampened cloth or sponge.
- Clean the Tabletop and accessories using an approved cleaner listed above.
- Clean all pads according to the instructions attached to the pad.
- Clean the table frame, castors, and base with Simple Green™ cleaner.
- Thoroughly rinse Patient Mattress Pad, Tabletop and Accessory Rails with water.
- Gently rub with a soft, clean cloth until dry.

CLEANING STEPS FOR RADIATION SHIELD:

- Remove the section from the table assembly and lay it flat before using the recommended cleaner in an adequately ventilated area.
- Apply approved cleaner to one side at a time and allow to stand a few minutes.
- Scrub with a soft bristle scrub brush. Do not let the solution dry before rinsing.
- Rinse with water and a damp cloth.
- Scrub and rinse again, if necessary.
- Allow shield to fully dry before reinstalling.

MAINTENANCE SERVICE AND REPAIR

All maintenance procedures should be done by an experienced and qualified technician with demonstrated knowledge and skills (electrical and mechanical) in the service of medical equipment. Never attempt to service/repair while the ME Equipment is in use.

- ✓ This individual must have access to this manual and the proper tools.
- ✓ Lubrication of this device is *not* required.

1.1. RECOMMENDED PERIODIC PERFORMANCE CHECKS

Daily	<ul style="list-style-type: none"> • Inspect all external cables, controls, and the tabletop for wear and damage. Damaged cables must be replaced promptly. This equipment uses a medical grade power cord which is not user serviceable. Replacement must be performed only by a qualified service technician. • Inspect wireless controllers for any indication of a low battery level. Battery level will vary depending on usage.
Weekly	<ul style="list-style-type: none"> • Check table base locking operation by locking front and rear casters mechanisms independently and lightly pushing on pedestal end of table to test each caster lock. • Check battery operation by disconnecting the AC power and running the tabletop up and down. • Run the tabletop through its full range of motions to help keep the actuators from sticking or freezing up.
Semi-annually	<ul style="list-style-type: none"> • Inspect carbon fiber tabletop.
Annually	<ul style="list-style-type: none"> • Replace batteries in wireless controllers (IDI recommends only using batteries with a no leak guarantee or equivalent)

1.2. SERVICE & REPAIR STATEMENT

Only qualified personnel should perform repairs on this equipment. Please read this entire document before performing any diagnostics or repairs. Some procedures listed require this device to be energized while repairs are performed; please exercise extreme caution while working with electrical components. Always exercise appropriate lockout/tag out procedure while performing any diagnostics and service on the table.

Image Diagnostics, Inc. may provide on request component part lists or other information to assist the user's appropriately qualified technical personnel to repair those parts of equipment which are designated by the manufacturer as repairable.



For technical assistance, call IDI at (978) 829-0009. Be prepared to give the complete model and serial number found on the data plate on the table base at the time of contact.

TROUBLESHOOTING

Note: The motion of the Tabletop is fully controlled by user interface with switches, buttons, and motorized panning. In the event of a loss of these motions it is expected that the tabletop will remain stationary without any unwanted movement.

Problem/Symptom	Possible Cause	Remedy
1. Table controls are not functioning/no table movement.	<ol style="list-style-type: none"> 1. No Power. 2. Battery is depleted. 3. Emergency Stop Pushbutton engaged. 4. Control connection. 5. Electromagnetic Interference. 6. Actuators uncalibrated. 7. Tabletop Hand/Foot Control failure. 	<ol style="list-style-type: none"> 1. Check electrical outlet. 2. Connect to AC Power. 3. Reset Emergency Stop Pushbutton. 4. Service Control connections/attempt to reconnect Bluetooth controller. Each controller will periodically need batteries changed depending on usage. 5. Refer to EMC Section of this manual. 6. Reinitialize Actuator Controller with Handset Control. 7. Attempt actuation with one controller connected at a time. Multiple inputs inhibit table movement.
2. Partial table movement.	<ol style="list-style-type: none"> 1. No Power. 2. Battery is depleted. 3. Emergency Stop Pushbutton engaged. 4. Controller Failure. 5. Control connection. 6. Actuator(s) uncalibrated. 7. Actuator Failure. 	<ol style="list-style-type: none"> 1. Check electrical outlet. 2. Connect to AC Power 3. Reset Emergency Stop Pushbutton. 4. Test motion with other foot/hand Control. If elevate works correctly, replace the original controller. 5. Service Control connections. 6. Reinitialize Actuator Controller with Handheld Control. 7. Replace Actuator related to movement.
3. Table movement slow.	<ol style="list-style-type: none"> 1. Running on Battery Power. 2. Actuator(s) uncalibrated. 	<ol style="list-style-type: none"> 1. Connect to AC Power. 2. Reinitialize Actuator Controller with Handset Control performing reset

DISPOSAL OF COMPONENTS



IDI medical tables are made up of mostly steel, copper and aluminum parts which are easily recycled. It is recommended that some components be disassembled before disposal for recycling. The table below lists components typically found in IDI products but varies with model and options.

COMPONENT	ITEM	RECYCLING GROUP
Actuators	Spindle and Motor Housing Cable	Metal (Steel and Copper) Plastic Copper
Control Box	PC Board Plastic Housing Cable Transformer Batteries	Electronic Plastic Copper Copper Lead Acid Batteries
Hand Controls	PC Board Housing Cable	Electronic Plastic Copper
Table Base	Frame Casters Covers	Metal (Steel) Plastic and Steel Stainless Steel

Electronic waste and batteries



Electronic components and devices must be disposed of according to local waste regulations. The symbol (left) denotes that the product contains electronic devices and cannot be disposed of with household waste. This product cannot be included in municipal waste and must be disposed or recycled according to local waste regulations.



Complies with FDA standards

PRODUCT DATA

Tabletop	Low attenuation carbon fiber tabletop and pad.
Tabletop surface	71 cm x 118 cm (28 in x 46.5 in)
Imaging area (main tabletop)	73.5 cm x 54.5 cm (29 in x 21.5in) max
Trendelenburg (tilt)	Approx. $\pm 12^\circ$ with automatic stop-at-level position.
Tabletop height range:	
<i>100-UC+</i>	74.3 cm to 104 cm (29.75 in to 41.5 in) without pad.
Longitudinal travel	35 cm (13.75 in)
Lateral (Cross Travel)	$\pm 88\text{mm}$ (± 3.5 in)
Patient capacity	249 kg (550lbs.) without tabletop extensions/accessories
Table Weight	$\sim 317.5\text{kg}$ ($\sim 700\text{lbs}$)
Emergency Stop	
Multi-caster locking system: Total Lock & Unlock	
Wireless Footswitch and Handset motion control	
Additional Wired Handset motion control optional.	
Backup battery power	
One Saved Memory Position	

SPECIFICATIONS

Mode of Operation

- For continuous use with short time loading.
- Duty Cycle: 10% (2 min on/18 min off).

Type of Equipment:

- Class 2 Type B applied part (as defined by IEC 60601-1, ANSI/AAMI ES60601-1, EN 60601-1, CAN/CSA 601.1-M90, IEC 60601-2-46:1998.)
- Type B protection against electrical shock as the applied part is the table surface.

Electrical:

- Supply Voltage: 120±5% Vac 60Hz or 230±5% Vac 50Hz.
- Duty Cycle: 10% (2 min on/18 min off).
- Current Rating: Less than 10 Amps.
- Battery Backup Power. (use Linak Li-Ion BA22 only. Output Voltage: 25.7 V DC, 1A max, 2.9 Ah/73.25Wh)

Environmental:

- Operating Temperature Range: -10°C to +40°C.
- Operating Humidity Range: 30% to 75% relative humidity, noncondensing.
- Operating Pressure Range: 700 hPa to 1060 hPa.
- Transport & Storage Temperature Range: -40°C to +60°C.
- Transport & Storage Humidity Range: 30% to 75% relative humidity, noncondensing.
- Transport & Storage Pressure Range: 500 hPa to 1060 hPa.
- Rated IPX4 (Protected against splashing water).
- Meets EMC requirements of IEC 60601-1-2:2007.

Tabletop:

- The tabletop is made of carbon fiber and meets all the requirements of FDA CFR Title 21, Chapter 1, Subchapter J.

Guidance and Manufacturer's Declaration- Emissions, All Equipment and Systems:**Table 1**

This equipment is intended for use in the electromagnetic environment specified below.

The customer or user of this equipment should ensure that it is used in such an environment.

Emissions Test	Compliance	Electromagnetic Environment – Guidance
RF Emissions CISPR 11	Group 1	This equipment uses RF energy only for its internal function. Therefore, its RF emissions are very low and not likely to cause any interference in nearby electronic equipment.
RF Emissions CISPR 11	Class A	This equipment is suitable for use in the professional healthcare facility environment.
Harmonics IEC 61000-3-2	Class A	
Flicker IEC 61000-3-3	Complies	
Specific Bluetooth components have been tested to standard FCC Part 15.247 and FCC Part 15 Rules respectively. For more information, please contact IDI for full certification documentation.		

Guidance and Manufacturer's Declaration- Immunity, All Equipment and Systems:
Table 2

This equipment is intended for use in the electromagnetic environment specified below.

The customer or user of this equipment should ensure that it is used in such an environment.

Immunity Test	EN/IEC 60601 Test Level	Compliance Level	Electromagnetic Environment Guidance
ESD EN/IEC 61000-4-2	±8kV Contact ±2kV, ±4kV, ±8kV, ±15kV Air	±8kV Contact ±2kV, ±4kV, ±8kV, ±15kV Air	Floors should be wood, concrete or ceramic tile. If floors are synthetic, the relative humidity should be at least 30%.
EFT EN/IEC 61000-4-4	±2kV at 100 kHz repetition frequency for AC Mains ±1kV at 100kHz repetition frequency for Signal I/O parts Port	±2kV Mains ±1kV I/Os	Main power quality should be that of a typical commercial or hospital environment.
Surge EN/IEC 61000-4-5	±0.5kV, ±1kV Line to Line ±0.5kV, ±1kV, ±2kV Line to Ground	±0.5 kV, ±1 kV Line to Line ±0.5kV, ±1kV, ±2 kV Line to Ground	Main power quality should be that of a typical commercial or hospital environment.
Voltage Dips/Dropout EN/IEC 61000-4-11	0 % UT; 0.5 cycle At 0°, 45°, 90°, 135°, 180°, 225°, 270° and 315° 0 % UT; 1 cycle 70 % UT; 25/30 cycles for 50 Hz and 60Hz, respectively Single phase: at 0° 0 % UT; 250/300 cycle for 50 Hz and 60 Hz, respectively Single phase: at 0°	0 % UT; 0.5 cycle At 0°, 45°, 90°, 135°, 180°, 225°, 270° and 315° 0 % UT; 1 cycle 70 % UT; 25/30 cycles for 50 Hz and 60Hz, respectively Single phase: at 0° 0 % UT; 250/300 cycle for 50 Hz and 60 Hz, respectively Single phase: at 0°	Main power quality should be that of a typical commercial or hospital environment. If the user of this equipment requires continued operation during power mains interruptions, it is recommended that this equipment be powered from an uninterruptible power supply or battery.
Power Frequency IEC 61000-4-8 Magnetic Field EN/IEC 61000-4-8	30A/m, 50Hz or 60Hz	30A/m, 50Hz or 60Hz	Power frequency magnetic fields should be that of a typical commercial or hospital environment.

Guidance and Manufacturer's Declaration Emissions, Equipment and Systems that are NOT Life-Supporting
Table 3

This equipment is intended for use in the electromagnetic environment specified below.

The customer or user of this equipment should ensure that it is used in such an environment.

Immunity Test	EN/IEC 60601 Test Level	Compliance Level	Electromagnetic Environment Guidance
Conducted RF EN/IEC 61000-4-6	AC Mains: 3V, 0.15MHz – 80MHz 6V in ISM band between 0.15MHz and 80MHz 80%AM at 1KHz [see table 5 of IEC 60601-1-2]	AC Mains: 3V, 0.15MHz – 80MHz 6V in ISM band between 0.15MHz and 80MHz 80%AM at 1KHz [see table 5 of IEC 60601-1-2]	Portable and mobile communications equipment should be separated from this equipment by no less than the distances calculated/listed below: $D=(3.5/3)(\text{Sqrt } P)$ 80 to 800 MHz $D=(7/3)(\text{Sqrt } P)$ 800 MHz to 2.7 GHz where P is the max power in watts and D is the recommended separation distance in meters.
	SIP/SOPS: 3V, 0.15MHz – 80MHz 6V in ISM band between 0.15MHz and 80MHz 80%AM at 1kHz [see table 5 of IEC 60601-1-2]	SIP/SOPS: 3V, 0.15MHz – 80MHz 6V in ISM band between 0.15MHz and 80MHz 80%AM at 1kHz [see table 5 of IEC 60601-1-2]	
Radiated RF EN/IEC 61000-4-3	3V/m 80MHz to 2.7GHz 80%AM at 1kHz	3V/m 80% AM	Field strengths from fixed transmitters, as determined by an electromagnetic site survey, should be less than the compliance levels (V1 and E1). Interference may occur in the vicinity of equipment containing a transmitter.

**Recommended Separation Distances between portable and mobile RF Communication Equipment and this equipment.
Equipment and Systems that are NOT Life-Supporting.**

Recommended Separations from this equipment is intended for use in the electromagnetic environment in which radiated disturbances are controlled. The customer or user of this equipment can help prevent electromagnetic interference by maintaining a minimum distance between portable and mobile RF Communications Equipment and this equipment as recommended below, according to the maximum output power of the Communications Equipment.

Table 4

Max Output Power (Watts)	Separation (m) 150kHz to 80MHz	Separation (m) 80 to 800MHz	Separation (m) 800MHz to 2.5GHz
	$D=(3.5/3)(\text{Sqrt } P)$	$D=(3.5/3)(\text{Sqrt } P)$	$D=(7/3)(\text{Sqrt } P)$
0.01	.1166	.1166	.2333
0.1	.3689	.3689	.7378
1	1.1666	1.1666	2.3333
10	3.6893	3.6893	7.3786
100	11.6666	11.6666	23.3333

WARRANTY & CONTACT INFORMATION

**Warranty details for IDI Products can be obtained directly from
Image Diagnostics, Inc.**



Image Diagnostics, Inc.
310 Authority Drive
Fitchburg, MA 01420 USA



Or call IDI at (978) 829-0009